

Ogni vite, dove è riportato il simbolo "Locktite", deve essere preventivamente impregnata di Locktite a tenuta media (blu).

Each screw identified by the "Locktite" symbol, must be impregnated with a small drop of medium seal Locktite (blue)

Wo das Symbol "Locktite" angebracht ist, muss jede Schraube vorsorglich mit Locktite mittelfest gesichert (blau) werden.

Chaque vis, où est reporté le symbole "Locktite", doit être au préalable imprégnée de Locktite à tenue moyenne (bleue).

Flat Washer d6,D8,W0.5

Ver. A

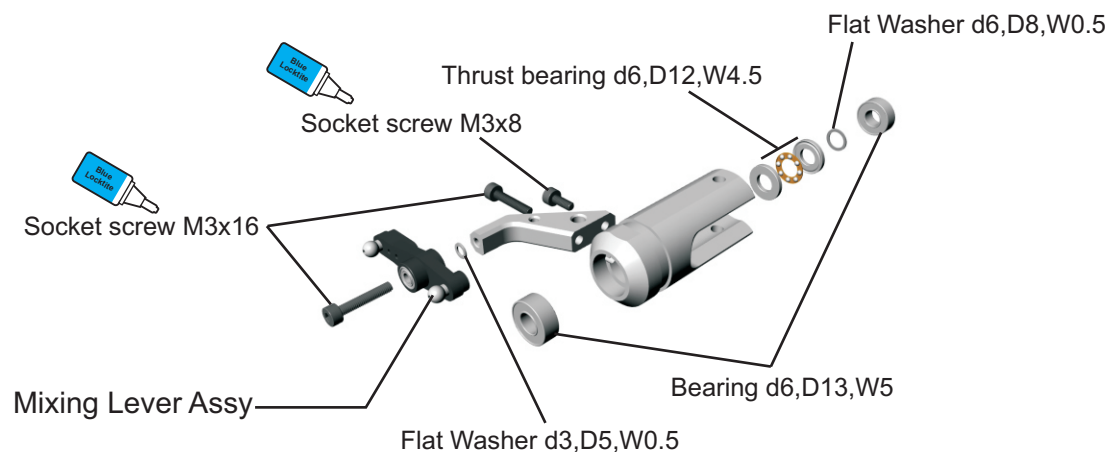

Flat Washer d9,D13,W0.5

Ver. B

